

# V850 G Plus



## Machine Tool V850G Plus

Maximum workpiece (mm)	1100 x 850 x 345 mm (43.3" x 33.5" x 13.6")
Max workpiece weight	1100 kg (2425 lb)
Travel of X/Y axes	800 x 500 mm (13.5" x 19.7")
Travel of U/V axes	160 x 160 mm (6.3" x 6.3")
Travel of Z axis	350, 410 or 498mm (13.8, 16.1 or 19.6")(Submerged height 310 mm(12.2"))
Wire diameter	0.15~0.3 mm (0.006" ~ 0.012")
Number of axes controlled 5	5 Axis AC servo motor
Max taper angle	±30°/100 mm (±30°/3.9") (with wide diamond guide and nozzle)
Machine size	2840 x 2900 x 2290 mm (111.8" x 114.2" x 90.2")
Machine weight	4900 kg (10802 lb)

## Dielectric Tank

Tank Capacity	1050L
Paper Filter	2 pcs
Deionizer & Chiller Unit	AUTO

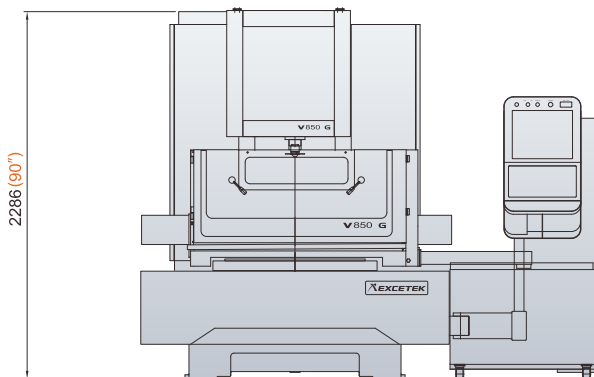
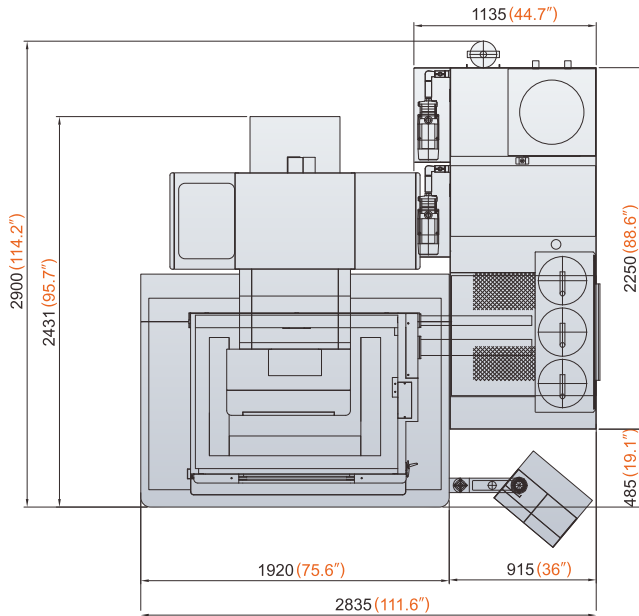

## Standard Accessories

- Ion exchange resin 10L(S)
- Paper filter x 2 pieces
- Diamond guide x 2 pieces
- Upper & Lower Flushing nozzle x 4 pieces
- Power contact x 2 pieces
- Brass wire Ø0,2 or Ø0,25 5kg x 1 wheel
- Wire alignment jig x 1 piece
- Clamping tool x 1 set

## Option

- X Y axis Linear scale
- AWT
- AVR
- City power Transformer
- Jumbo Feeder 50kg



7697 Innovation Way  
 Mason, OH 45040  
 513.701.0441  
 globaledm.com