

V650 G Plus



Machine Tool V650G Plus

Maximum workpiece (mm)	1000 x 700 x 345 mm (39.4" x 27.6" x 13.6")
Max workpiece weight	800 kg (1764 lb)
Travel of X/Y axes	650 x 400 mm (25.6" x 15.7")
Travel of U/V axes	160 x 160 mm (6.3" x 6.3")
Travel of Z axis	350, 410, 498 or 800mm (13.8, 16.1, 19.6 or 31.5") (Submerged height 310 mm) (12.2")
Wire diameter	0.15~0.3 mm (0.006" ~ 0.012")
Number of axes controlled 5	5 Axis AC servo motor
Max taper angle	±30°/100 mm (±30°/3.9") (with wide diamond guide and nozzle)
Machine size	2520 x 2720 x 2290 mm (99.2" x 107.1" x 90.2")
Machine weight	4450 kg (9810 lb)

Dielectric Tank

Tank Capacity	850L
Paper Filter	2 pcs
Deionizer & Chiller Unit	AUTO

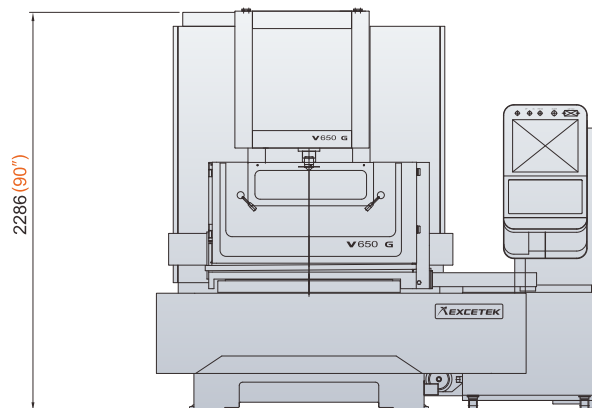
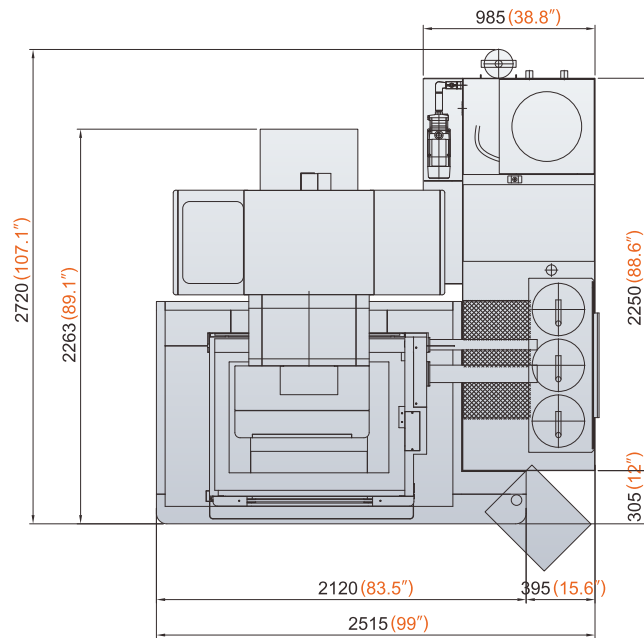

Standard Accessories

- Ion exchange resin 10L(S)
- Paper filter x 2 pieces
- Diamond guide x 2 pieces
- Upper & Lower Flushing nozzle x 4 pcs.
- Power contact x 2 pieces
- Brass wire Ø0,2 or Ø0,25 5kg x 1 wheel
- Wire alignment jig x 1 piece
- Clamping tool x 1 set

Option

- X Y axis Linear scale
- AWT
- AVR
- City power Transformer
- Jumbo Feeder 50kg



7697 Innovation Way
 Mason, OH 45040
 513.701.0441
 globaledm.com